

INSTRUCTION MANUAL

RANKOR

LITHIUM-ION ROTARY HAMMER
RLHD20002



Made in China 0725-V01
www.rankortools.com

READ AND FOLLOW ALL SAFETY PRECAUTIONS IN THE INSTRUCTION MANUAL.

Thank you for choosing **RANKOR** tools.

RANKOR products are renowned for their reliability, high performance, and superior quality. Our team is committed to continuous innovation, providing customers with upgraded tools and a comfortable user experience. Additionally, we offer exceptional after-sales service and promise to resolve any technical issues for our customers as swiftly as possible.

Before operating the tools, please read all warnings, cautions, and instructions on the tool labels and in the owner's manual. Note that the safety information provided does not cover all potential conditions or situations that may arise. Thoroughly review the owner's manual for complete safety guidelines and operating procedures. Failure to follow the instructions and safety information may lead to severe **INJURY** or **DEATH**.

CONTENTS

SAFETY NOTES	2
PRODUCT OVERVIEW	8
SPECIFICATION	8
ASSEMBLY AND INSTALLATION	9
OPERATING INSTRUCTIONS	10
MAINTENANCE	11
TROUBLESHOOTING	11
SPARE PARTS LIST	12
EXPLODED VIEW	13

SAFETY NOTES



WARNING: Read all safety warnings and all instructions. Failure to follow the warnings and instructions may result in electric shock, fire, or severe injury. Save all warnings and instructions for future reference.

The term “power tool” in the safety notes refers to your mains-operated (corded) power tool or battery-operated (cordless) power tool.

General safety notes

1. Work area safety

- 1) DO NOT operate power tools in explosive atmospheres, such as in flammable liquids, gases or dust. Power tools create sparks that may ignite the dust or fumes.
- 2) Keep the work area clean and well-lit. Cluttered or dark areas invite accidents.
- 3) Keep children and bystanders away while operating a power tool. Distractions can cause loss of control.

2. Electrical safety

- 1) DO NOT expose the tool to rain or wet conditions. Moisture entering the tool may increase the risk of electric shock or cause malfunction.
- 2) DO NOT attempt to open or modify the internal electrical components. Unauthorized tampering may lead to electric shock or serious malfunction.
- 3) Use the tool only with compatible power sources as specified by the manufacturer.
- 4) Avoid body contact with earthed or grounded surfaces such as pipes, radiators, ranges, and refrigerators. Contact with such surfaces increases the risk of electric shock.
- 5) Keep the tool clean and dry. Contamination with conductive materials such as dust, metal shavings, or moisture may lead to short circuits.

3. Personal safety

- 1) DO NOT overreach. Keep proper footing and balance at all times. This enables better control of the power tool in unexpected situations.
- 2) DO NOT use a power tool while the user is tired or under the influence of drugs, alcohol or medication. A moment of inattention while operating power tools may result in serious personal injury.
- 3) DO NOT wear loose clothing or jewellery. Keep hair, clothing and gloves away from moving parts. Loose clothes, jewellery or long hair can be caught in moving parts.
- 4) Stay alert, watch what you are doing and use common sense when operating a power tool.
- 5) Use personal protective equipment. Always wear eye protection. Protective equipment such as dust masks, non-skid safety shoes, hard hats, and hearing protection for appropriate conditions will reduce personal injuries.
- 6) Prevent accidental activation. Always verify the power switch is in the OFF position before connecting to a power source, transporting, or handling the device. Never carry the tool with your finger on the switch or operate it while the switch is engaged, as this may lead to hazardous situations.
- 7) Remove all adjustment tools before operation. Ensure any wrenches or keys are detached from the device before powering it on. Leaving tools attached to rotating components can cause serious injury.
- 8) If devices are provided for connecting dust extraction and collection facilities, ensure these are connected and properly used. The use of dust collection can reduce dust-related hazards.

4. Power tool use and care

- 1) DO NOT force the power tool. Use the correct power tool for your application. The correct power tool will do the job better and safer at the rate for which it was designed.
- 2) DO NOT use the power tool if the switch does not turn on and off. Any power tool that cannot be controlled with the switch is dangerous and must be repaired.
- 3) Keep cutting tools sharp and clean. Properly maintained cutting tools with sharp edges are less likely to bind and are easier to control.

- 4) Disconnect the plug from the power source or the battery pack from the power tool before making any adjustments, changing accessories, or storing power tools. Such preventive safety measures reduce the risk of starting the power tool accidentally.
- 5) Store idle power tools out of the reach of children and do not allow persons unfamiliar with the power tool or these instructions to operate the power tool. Improper use of power tools by untrained individuals may result in serious injury or property damage.
- 6) Maintain power tools. Check for misalignment or binding of moving parts, breakage of parts and any other condition that may affect the power tool's operation. If damaged, have the power tool repaired before use. Failure to properly maintain power tools can lead to malfunction and increase the risk of accidents.
- 7) Use the power tool, accessories, tool sets, etc., in accordance with these instructions, taking into account the working conditions and the work to be performed. Using the power tool for operations different from those intended could result in a hazardous situation.

Additional safety notes for lithium battery tools

1. Safety notes for battery charger



WARNING: Shock hazard. DO NOT allow any liquid to get inside the charger.



CAUTION: Burn hazard. To reduce the risk of injury, charge only designated batteries. Other types of batteries may burst to cause personal injury and damage.



CAUTION: Under certain conditions, with the charger plugged into the power supply, the charger can be shorted by foreign material. Foreign materials of a conductive nature, such as but not limited to steel wool, aluminum foil, or any buildup of metallic particles, should be kept away from charger cavities. Always unplug the charger from the power supply when there is no battery pack in the cavity. Unplug the charger before attempting to clean.

- 1) DO NOT expose the charger to rain or snow.
- 2) DO NOT attempt to connect two chargers together.
- 3) DO NOT operate chargers with damaged cords or plugs - have them replaced immediately.
- 4) DO NOT operate the charger if it has received a sharp blow, been dropped, or otherwise damaged in any way.
- 5) DO NOT disassemble the charger. Incorrect reassembly may result in a risk of electric shock, electrocution, or fire.
- 6) DO NOT use an extension cord. Use of an improper extension cord could result in a risk of fire, electric shock, or electrocution.
- 7) Put the charger in the room where the temperature is between 50°F and 72°F (10°C and 22°C).
- 8) The battery charger should be stored in a dry environment and prevent any possible moisture from entering.
- 9) Always pull the charger by the plug, not the cord, when disconnecting it. This helps prevent damage to the plug and power cord.
- 10) Make sure that the cord of the charger is located suitably so that it will not be stepped on, tripped over, or otherwise subjected to damage or stress.
- 11) Disconnect the charger from the outlet before attempting any cleaning. This will reduce the risk of electric shock. Removing the battery pack will not reduce this risk.
- 12) The charger is designed to operate on standard household electrical power. DO NOT use it with incompatible power sources.
- 13) Always recharge the battery exclusively with the manufacturer-specified charger. The charger and battery pack are specifically designed to work together. Using an incompatible charger may pose a fire hazard.
- 14) These chargers are not intended for any uses other than charging designated rechargeable batteries. Any other uses may result in the risk of fire, electric shock, or electrocution.

2. Safety notes for battery pack

- 1) DO NOT strike or puncture the battery, as it may cause explosion or fire.
- 2) DO NOT attempt to repair the damaged battery packs or the battery charger.
- 3) DO NOT incinerate the battery pack even if it is severely damaged or is completely worn out. The battery pack could explode in fire. Toxic fumes and materials are created when battery packs are burned.
- 4) DO NOT place the battery pack in water or let it get wet in the rain. Short circuit of battery will generate large current due to overheating and may cause fire or even breakdown.
- 5) DO NOT charge or use the battery in explosive atmospheres, such as in the presence of flammable liquids, gases, or dust. Inserting or removing the battery from the charger may ignite dust or fumes.
- 6) Charge the hot battery pack only after cooling it down.
- 7) Recharge only with the charger specified by the manufacturer.
- 8) Never attempt to open the battery pack for any reason. If the plastic housing of the battery pack breaks or cracks, return to a service center for recycling.
- 9) Use equipment only with specifically designated battery packs. Use of any other battery packs may cause a risk of injury and fire.
- 10) Avoid deep discharge. When the tool shows low power, stop using it and recharge promptly to extend battery life.
- 11) The battery pack is equipped with overcharge protection. DO NOT repeatedly restart charging cycles after it is fully charged.
- 12) When not in use, keep the battery pack away from metal objects such as coins, keys, or screws that may cause a short circuit and result in fire or burns.
- 13) Under extreme conditions, batteries may eject hazardous liquids. Avoid skin contact. If exposed, immediately rinse affected areas with water. For eye contact, flush thoroughly with water and seek urgent medical attention. The expelled liquid may cause chemical irritation or burns. The electrolyte in lithium-ion batteries contains organic carbonates and lithium salts.
- 14) Damaged or misused batteries may release vapors, potentially causing respiratory irritation or explosion. Use the battery in well-ventilated areas and seek medical help if symptoms occur. Stop using the battery if it shows abnormal performance, such as reduced runtime or overheating.

3. Battery protection system



WARNING: Burn hazard. Battery liquid may be flammable if exposed to sparks or flame.



CAUTION: Fire hazard. DO NOT store or carry batteries with exposed terminals in conditions where they may contact metal objects (e.g., nails, screws, keys). Battery terminals must be protected against short circuits during storage and transportation.



NOTICE: Lithium-ion batteries must not be placed in checked baggage.

- 1) DO NOT immerse the battery pack in water or other liquids.
- 2) DO NOT store or use the battery pack or tool in locations where temperatures may exceed 40°C (105°F), such as metal buildings or enclosed vehicles in summer.
- 3) DO NOT attempt to open, crush, drop, or damage the battery pack.
- 4) DO NOT insert a cracked or damaged battery pack into the charger.
- 5) DO NOT use or charge any battery pack that has been dropped, crushed, or damaged in any way.
- 6) Charge battery packs only with chargers specified by the manufacturer.
- 7) The battery pack is equipped with a protection system that automatically cuts off motor output to prolong tool and battery life.

8) The tool may stop running during use if the system is activated due to the following conditions. This does not indicate a malfunction:

Overload condition: Release the trigger and eliminate the cause of the overload.

Low battery: Recharge the battery pack before use.

Automatic power cut-off: If the tool does not restart after releasing the trigger, recharge the battery.

4. Battery storage suggestion

1) The best storage place is one that is cool and dry, away from direct sunlight and excess heat or cold.

2) Long-term storage will not harm the battery pack or charger.



NOTICE: Lithium-ion battery packs should not be constantly kept in the state that power is exhausted.

When you don't use your batteries very often, charge the battery to approximately 50% capacity at least once every six months.

5. Important charging notes

1) DO NOT charge the battery if the ambient temperature is below +4.5°C (40°F) or above +40.5°C (105°F), as this may result in battery damage.

2) For optimal battery life and performance, charge the battery pack in ambient temperatures between 18°C and 24°C (65°F–75°F).

3) It is normal for the charger and battery pack to become warm during charging.

4) To assist cooling after use, do not place the charger or battery pack in high-temperature environments such as metal sheds or uninsulated trailers.

5) Recharge the battery pack if it fails to provide expected runtime or performance. Partial charging is allowed and will not harm the battery.

6) If the battery pack does not charge properly:

Verify the outlet is functioning by plugging in another device (e.g., a lamp).

Move the charger and battery to an environment with air temperature around 18°C–24°C (65°F–75°F).

Inspect whether the outlet is controlled by a wall switch that may be cutting power when lights are turned off.



WARNING: Shock hazard. DO NOT allow any liquid to enter the charger.



WARNING: DO NOT attempt to open the battery pack for any reason.

Service

Have your power tool serviced by a qualified repair person using only identical replacement parts. This will ensure that the safety of the power tool is maintained.

Rotary hammer safety warnings

1) Wear ear protectors. Exposure to noise can cause hearing loss.

2) Use a dust mask or respirator for applications which generate dust.

3) Use auxiliary handle, if supplied with the tool. Loss of control can cause personal injury.

4) Hold the power tool by insulated gripping surfaces, when performing an operation where the cutting accessory or fasteners may contact hidden wiring or its own cord. Cutting accessory contacting a "live" wire may make exposed metal parts of the power tool "live" and could give the operator an electric shock.

5) When using long drill bit, always start drilling at low speed and with the bit tip in contact with the workpiece. At higher speeds, the bit is likely to bend if allowed to rotate freely without contacting the workpiece, resulting in personal injury.

- 6) When using long drill bit, apply pressure only in direct line with the bit and not apply excessive pressure. Bits can bend causing breakage or loss of control, resulting in personal injury.
- 7) Use suitable detectors to determine if there are hidden supply lines or contact the local utility company for assistance. Contact with electric cables can cause fire and electric shock. Damaging gas lines can lead to explosion. Breaking water pipes causes property damage.
- 8) The application tool may jam during drilling. Make sure you have a stable footing and hold the power tool firmly with both hands. Otherwise you could lose control of the power tool.
- 9) Be sure no one is below when using the tool in high locations.
- 10) Take care when carrying out demolition work using the chisel. Falling fragments of the demolition material could injure you or any bystanders.
- 11) Always wait until the power tool has come to a complete stop before placing it down. The application tool can jam and cause you to lose control of the power tool.
- 12) Do not touch any application tools or adjacent housing components shortly after operation. These can become very hot during operation and cause burns.
- 13) Disconnect battery pack from tool before making any assembly, adjustments or changing accessories. Such preventive safety measures reduce the risk of starting the tool accidentally

Additional safety instructions for your battery pack

- 1) Before using battery, read all instructions and cautionary markings in this manual, on battery charger, battery pack, and product using battery.
- 2) Battery pack needs to be charged before use. Always refer to this instruction and use the correct charging procedure.
- 3) Do not use any battery pack which is not designed for use with the equipment.
- 4) Observe the plus (+) and minus (-) marks on the battery pack and equipment and ensure correct use.
- 5) Immediately discontinue use of the battery if, while using, charging or storing the battery, the battery emits an unusual smell, feels hot, changes color or shape, or appears abnormal in any other way.
- 6) If operating time has become excessively shorter, stop operating immediately. It may result in a risk of overheating, possible burns and even an explosion.
- 7) Be careful not to drop or strike battery. Never use the battery pack as a hammer, beat the battery pack could result in accident short, fire or explode.
- 8) Remove the battery pack from the equipment when not in use.
- 9) Do not short-circuit a battery pack. Do not store battery packs haphazardly in a box or drawer where they may short-circuit each other or be short-circuited by other metal objects. When battery pack is not in use, keep it away from other metal objects, like paper clips, coins, keys, nails, screws or other small metal objects, and that can make a connection from one terminal to another. Shorting the battery terminals together may cause burns or fire.
- 10) Wipe the battery pack terminals with a clean dry cloth if they become dirty.
- 11) Keep battery pack clean and dry.
- 12) Do not store the tool and battery pack in locations where the temperature may reach or exceed +50°C (122°F), and may reach or below -20°C (-68°F).
- 13) Do not expose battery pack to heat or fire. Avoid storage in direct sunlight.
- 14) Keep the battery pack away from microwaves and high pressure.
- 15) Keep the battery pack out of the reach of children.
- 16) In the event of battery leaking, do not allow the liquid to come in contact with the skin or eyes. If contact has been made, wash the affected area with copious amounts of water and seek medical advice.
- 17) Do not dismantle, open or shred cells or battery pack.
- 18) Do not incinerate the battery pack even if it is severely damaged or is completely worn out. The battery pack can explode in a fire.
- 19) Do not dispose of batteries in fire, or with household waste. Return exhausted batteries to your local collection or recycling point.
- 20) After extended periods of storage, it may be necessary to charge and discharge the battery pack several times to obtain maximum performance.
- 21) Always purchase the battery pack recommended by the device manufacturer for the equipment.

Additional safety instructions for your charger

- 1) Before charging, read all instructions and cautionary markings in this manual, on battery charger, battery, and product using battery.
- 2) Before using charger, be sure the supply is the same as the voltage given on the nameplate of the charger.
- 3) Do not use chargers for works other than those for which they are designed.
- 4) Do not charge a leaking battery back.
- 5) Do not recharge non-rechargeable batteries, as they can overheat and break.
- 6) Do not charge the batteries of other manufactures or ill-suited models.
- 7) Charger is for indoor use only. Do not expose charger to rain or snow. Do not recharge battery in damp or wet environment.
- 8) Place charger on flat non-flammable surfaces and away from flammable materials such as paper, textile and so on when charging battery pack.
- 9) Always charge the battery pack between temperatures 0°C-40°C (32°F - 104°F). Ideal charging temperatures is 10°C - 30°C (50°F - 86°F).
- 10) Ensure that the connection between the battery charger and battery is correctly positioned and is not obstructed by foreign bodies.
- 11) When charging batteries, ensure that the battery charger is in a well-ventilated area and away from inflammable materials. Batteries can get hot during charging. Do not overcharge any batteries. Ensure that batteries and chargers are not left unsupervised during charging.
- 12) Always remove the battery pack from the charger immediately after charging is completed.
- 13) To unplug charger from outlet when you do not use the charger.
- 14) Keep battery charger's slots are free of foreign objects and protect against dirt and humidity.
- 15) Store charger in a dry and frost-free place.
- 16) If the charger supply cord is damaged, it must be replaced by the manufacturer, its service agent or similarly qualified persons in order to avoid a hazard.

Residual risk

Even if you use the rotary hammer properly and follow all safety notes, there are always residual risks. The following risks may occur:

- 1) Lung injury if a suitable dust mask is not worn.
- 2) Hearing loss if suitable ear protection is not worn.
- 3) Eye injury caused by flying materials or parts if no suitable eye protection is worn.
- 4) Injury to health attributed to hand-arm vibration if the rotary hammer is used for a prolonged period of time.
- 5) Risk of injury if long hair, loose-fitting clothing, or jewellery get caught by rotating parts of the rotary hammer.
- 6) Reduce residual risks by using the rotary hammer with care and following all safety notes as well as other instructions.

PRODUCT OVERVIEW

Fig. A

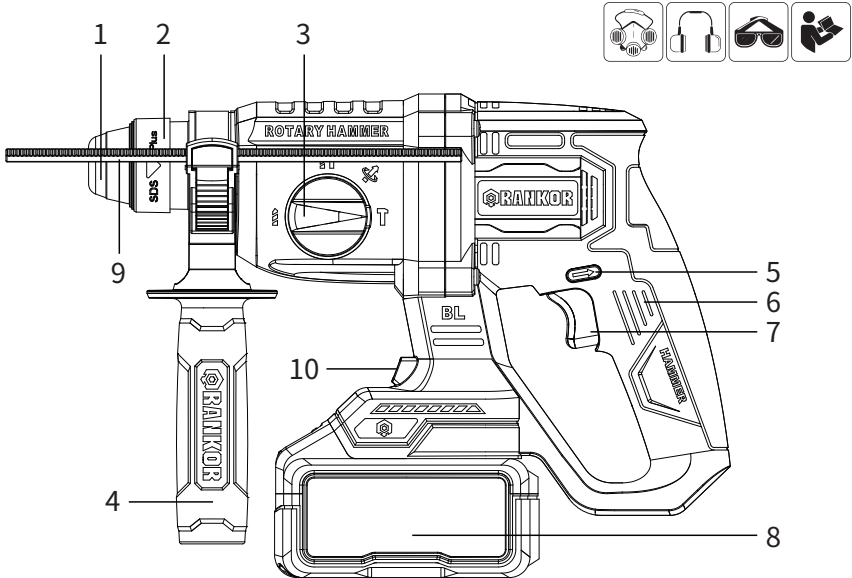

- 1. SDS+ Accessory Holder
- 2. Locking Sleeve
- 3. Function Selector

- 4. Front Handle
- 5. Forward/Reverse Lever
- 6. Rear Handle

- 7. Speed control switch
- 8. Battery
- 9. Metal Depth Rod
- 10. LED Light

SPECIFICATION

Product Model Name	RLHD20002
Battery rated voltage	20V
Battery	Li-ion
No Load Speed	0-1650/min
Impact Rate	0-5500bpm
Impact energy	2.5J
Chuck system	SDS-plus
Max.dring capacity	
Concrete:	22mm
Steel:	13mm
Wood:	28mm

⚠ Note: For power tool specifications refer to the nameplate on your power tool.

ASSEMBLY AND INSTALLATION

Adjusting the front handle

- 1) Loosen the front handle (4) by turning it counterclockwise and positioning it around the drill axis to a convenient working position.
- 2) Tighten the front handle (4) by turning it clockwise.

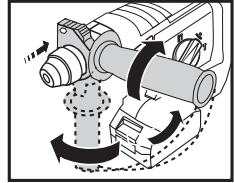

Mounting and adjusting the depth stop

- 1) Press the button on the front handle (4) to release it, and then insert the metal depth rod (9) into the hole on the front handle (4).
- 2) Adjust the metal depth adjustment rod (9) to the desired depth and release the button of the front handle (4).
- 3) Drill a test hole if necessary.

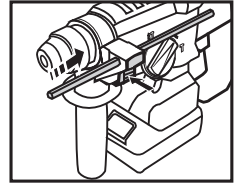

Inserting and removing SDS+ drill bits and accessories

WARNING! Ensure the rotary hammer's speed control switch is released and has come to a complete stop before inserting and removing SDS+ drill bits and accessories (not included).

- 1) Insert the drill bit in a twisting manner into the SDS+ Accessory Holder until it latches itself.
- 2) Check if the drill bit is latched in place by pulling it out.
- 3) Push back the locking sleeve on the machine. Pull the drill bit out to remove.

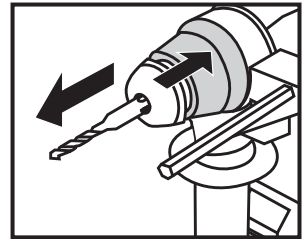
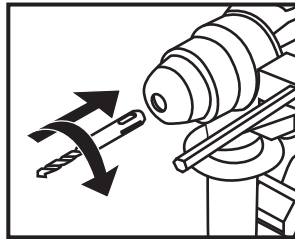
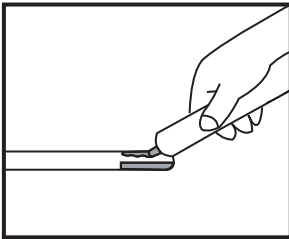

Insert and remove the battery pack solid separately

WARNING! Before inserting or removing the battery pack, make sure the rotary hammer is switched off.

- 1) To insert the battery pack, align the battery pack with the rotary hammer's base and slide the battery pack into the rotary hammer, so that the battery pack is locked in position.
- 2) To remove the battery pack, press the battery's release button and pull the battery pack out at the same time.

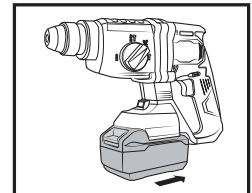
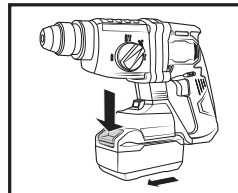

Turning the rotary hammer on or off

WARNING! Ensure the rotary hammer's speed control switch is released and has come to a complete stop before changing the rotation direction.

- 1) Select the direction of rotation by pushing the forward/reverse lever (5) to the left or right. When the forward/reverse lever (5) is in the middle, the speed control switch (7) is locked.
- 2) Hold the drill firmly in the position you want to drill. Turn on the rotary hammer by depressing the speed control switch (7). Increasing the pressure on the speed control switch (7) will increase the speed of the rotary hammer. Decreasing the pressure on the speed control switch (7) will decrease the speed of the rotary hammer.
- 3) Turn off the rotary hammer by releasing the speed control switch (7).
- 4) Do not force the tool. Light pressure gives the best result. Keep the tool in position and prevent it from slipping away from the hole.
- 5) Do not apply more pressure when the hole becomes clogged with chips or particles.
- 6) Ensure the workpiece is clamped and secured where possible.

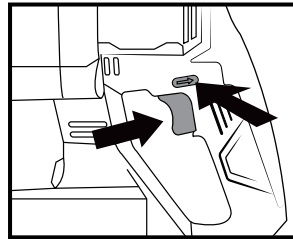
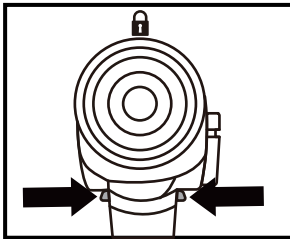



OPERATING INSTRUCTIONS

Choosing an operation mode:

WARNING! Ensure the rotary hammer's speed control switch is released and has come to a complete stop before changing the operation mode.

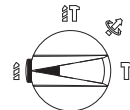
1) Drilling  - for drilling wood and metal



2) Hammer Drilling  - for drilling concrete and masonry



3) Chisel position adjustment  - for adjusting the chiseling position (Varil-Lock)



4) Chiselling  - for chiselling

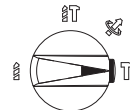

MAINTENANCE

 **WARNING!** Remove the battery from the rotary hammer before cleaning, maintenance, and storage.

Cleaning

- 1) Regularly clean the rotary hammer's housing with a soft cloth, preferably after each use. If the dirt does not come off, use a soft cloth moistened with soapy water.
- 2) Never use solvents such as petrol, alcohol, ammonia water, etc. These solvents may damage the plastic parts.

Maintenance

- 1) This rotary hammer has been designed to operate over a long period of time with a minimum of maintenance. Continuous satisfactory operation depends upon proper care and regular cleaning.
- 2) Your rotary hammer should only be repaired by an authorized service center. There are no serviceable parts that can be repaired by the user.

Storage

- 1) Thoroughly clean your rotary hammer and its accessories before storage.
- 2) Store the rotary hammer and its accessories out of the reach of children in a stable and secure place.

TROUBLESHOOTING

Problem	Possible causes	Possible solutions
Cannot start	Battery pack not installed properly.	Remove and insert the battery pack again.
	Battery not charged.	Charge the battery.
	Internal damage or wear e.g. motor is damaged.	Repair by an authorized service centre.
Can only run slowly	Battery is not charged.	Charge the battery.
	Battery wears out.	Replace the battery with a new one.
Overheat	Ventilation vents blocked.	Clean the dust from the ventilation vents.
	The rotary hammer is running for too long.	Turn off the drill and let it cool down.

RLHD20002 LITHIUM-ION ROTARY HAMMER SPARE PARTS LIST

Exploded View NO.	Part Name	QTY	Exploded View NO.	Part Name	QTY
1	Rubber Cap	1	42	Upper Block	1
2	Reverse-shaft Circlip	1	43	Shaft	1
3	Chuck Cover	1	44	Spring	1
4	Washer	1	45	Down Block	1
5	Locating Seat	1	46	Spring	1
6	Iron Ring	1	47	Needle Bearing	3
7	Ball	1	48	Circlip for Shaft	1
8	Washer	1	49	Synchronous Gear	1
9	Tower Spring	1	50	Clutch	1
10	Bush Seal	1	51	Shaft	1
11	Sleeve	1	52	Shaft Block	1
12	Ball Bearing	1	53	Clutch	1
13	Circlip for Shaft	2	54	Lever Bearing	1
14	Washer	1	55	Gear	1
15	Spring	1	56	Aluminum Bracket	1
16	Overrunning Clutch Gear	1	57	Press Plate	1
17	Lacating Ring	1	58	O-ring	1
18	Cylindrical Pin	2	59	Wool Rope	1
19	Cylinder	1	60	O-ring	1
20	Gear Box	1	61	Oil Ring	1
21	O-ring	1	62	Ball Bearing	1
22	Front-spacing Ring	1	63	Rotor	1
23	Impact Bolt	1	64	Ball Bearing	1
24	Bolt Cover	1	65	Stator	1
25	O-ring	1	66	Tapping Screw	9
26	O-ring	1	67	Right Housing	1
27	Back-spacing Ring	1	68	Switch	1
28	Circlip For Hole	1	69	Push Rod	1
29	Piston	1	70	Left Housing	1
30	O-ring	1	71	Tapping Screw	4
31	Aluminum Cylinder	1	72	Light Cover	1
32	Washer	2	73	Terminal D	1
33	Shaft	1	74	Pillar	2
34	Busing	1	75	Control Plate	1
35	Z-wire	1	76	Grip Spring	1
36	O-ring	1	77	T-screw	1
37	Adjust-knob	1	78	Grip Base	1
38	Spring	1	79	Depth Guage	1
39	Block Button	1	80	Button Spring	1
40	Block	1	81	Button	1
41	Spring	1	82	Handle	1

RLHD20002 LITHIUM-ION ROTARY HAMMER EXPLODED VIEW

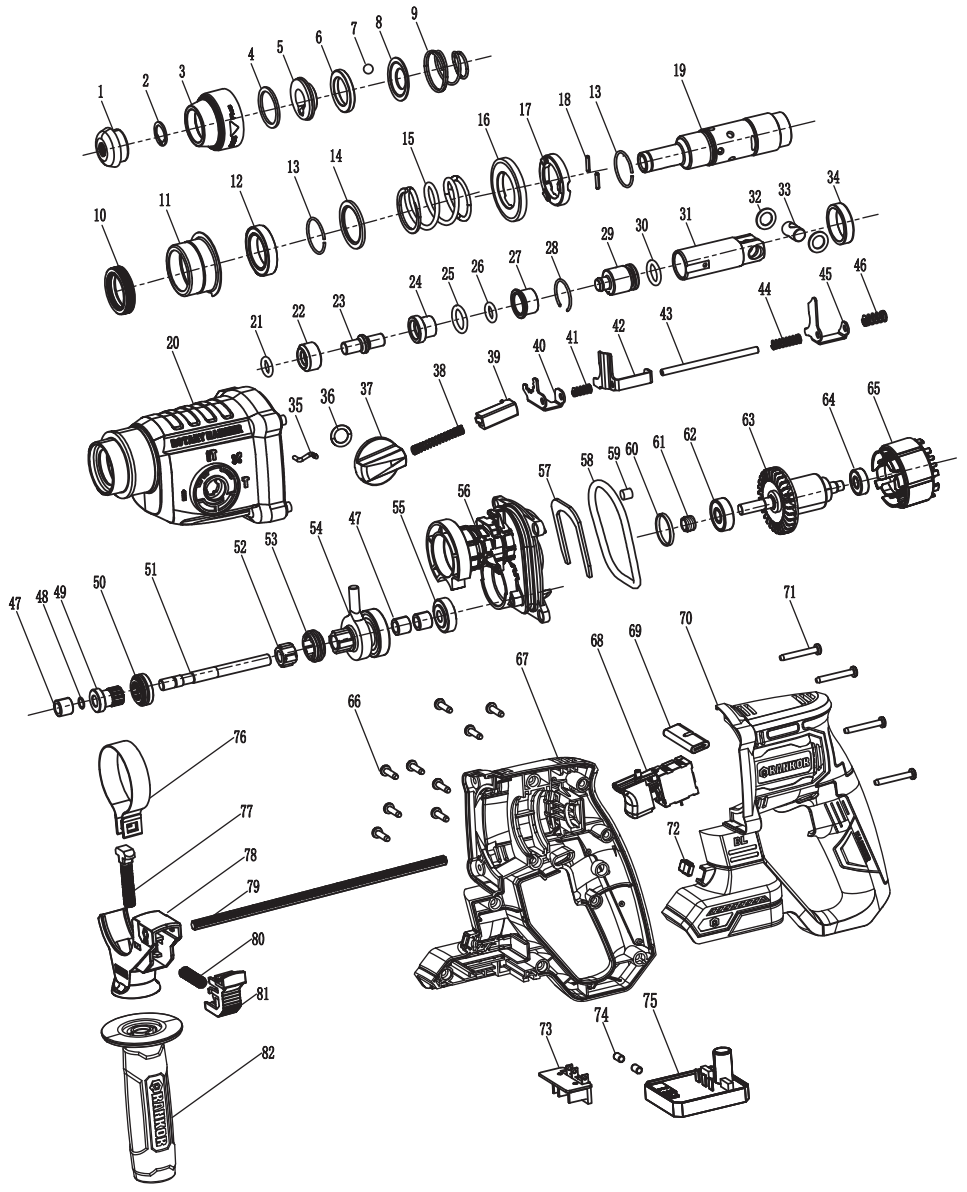

 **RANKOR**