

INSTRUCTION MANUAL

RANKOR

GASOLINE CHAIN SAW
RGCS5301



Made in China 0925-V01
www.rankortools.com

READ AND FOLLOW ALL SAFETY PRECAUTIONS IN THE INSTRUCTION MANUAL.

CONTENTS

1. Product Overview	2
1.1 Intended use	2
1.2 Layout	2
2. Specifications	3
3. Safety Notes	3
3.1 Explanation of symbols	3
3.2 Risk of fire or explosion	4
3.3 Risk of toxic emissions	4
3.4 Risk of mechanical injury	4
3.4.1 Kickback	4
3.4.2 Other operating warnings	5
3.5 Fuel handling	5
3.6 General safety notes	6
3.6.1 Work area safety	6
3.6.2 Personal safety	6
3.6.3 Gasoline-powered tool use and care	6
3.6.4 Service	7
3.7 Maintenance and storage safety	7
3.8 Residual risks	7
4. Assembly And Installation	8
4.1 Assembling the chain guide	8
4.2 Adjusting the chain tension	9
4.3 Filling the fuel tank	9
4.3.1 Mixing	9
4.3.2 Filling	9
5. Operating Instructions	9
5.1 Starting and stopping the engine	10
5.1.1 Starting	10
5.1.2 Stopping	10
5.2 Adjusting the carburetor	10
5.3 Chain brake and chain	11
5.3.1 Chain brake	11
5.3.2 Sharpening the chain	11
5.3.3 Checking chain lubrication	11
5.4 Cutting work	12
5.4.1 Tree felling	12
5.4.2 Cutting a fallen trunk	12
5.4.3 Pruning	12
6. Maintenance	13
6.1 After each use	13
6.2 Cleaning the air filter	13
6.3 Cleaning the oil and fuel filters	13
6.4 Guide bar	13
6.5 Sprocket	14
6.6 Spark plug	14
6.7 Chain saw	14
6.8 Chain sharpening	14
6.9 Storage	15
7. Troubleshooting	15

Thank you for choosing **RANKOR** tools.

RANKOR products are renowned for their reliability, high performance, and superior quality. Our team is committed to continuous innovation, providing customers with upgraded tools and a comfortable user experience.

Before operating the tools, please read all warnings, cautions, and instructions on the tool labels and in the owner's manual. Note that the safety information provided does not cover all potential conditions or situations that may arise. Thoroughly review the owner's manual for complete safety guidelines and operating procedures. Failure to follow the instructions and safety information may lead to severe **INJURY** or **DEATH**.

1. Product Overview

1.1 Intended use

The gasoline chain saw is intended solely for outdoor cutting and trimming of wood and must not be used on non-wood materials or indoors.

1.2 Layout

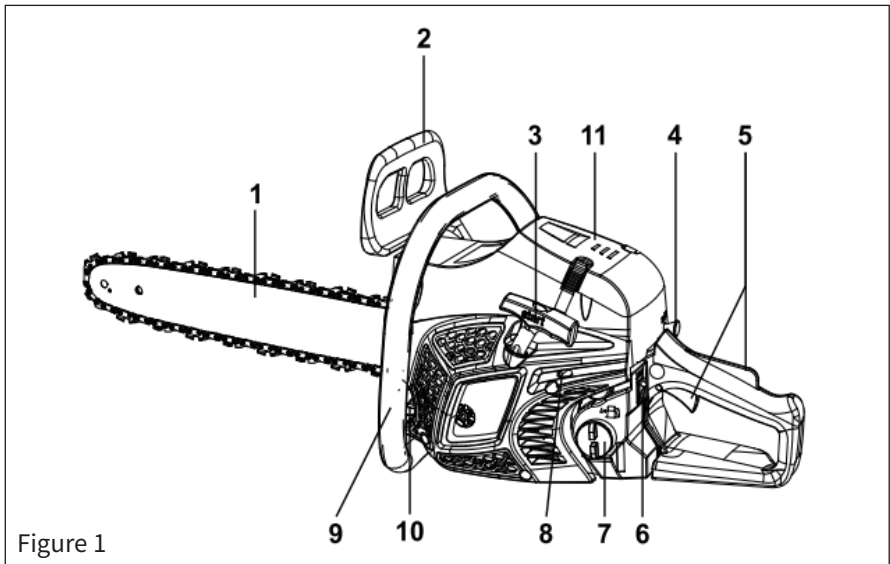

Figure 1

• The numbers in the diagram correspond to the part names listed in the table below.

1. Guide Bar	4. Choke	7. Fuel Tank	10. Oil Tank
2. Chain Brake	5. Throttle Trigger	8. Needle	11. Air Filter Cover
3. Starter	6. Switch	9. Handle	

Not all the accessories illustrated or described are included in standard delivery.

2. Specifications















Model	RGCS5301
Fuel Tank Volume	550ml
Oil Tank Volume	260ml
Idle Speed	3100±300/min
Maximum Power	2.2KW
Displacement	53CC
Maximum Engine Speed	11000/min
Chain Pitch	3/8"
Chain Gauge	0.063"
Sound Power Level	114 dB(A)
Mixture of Ratio	40:1

3. Safety Notes



WARNING: Read all safety warnings and all instructions. Failure to follow the warnings and instructions may result in fire or severe injury. Save all warnings and instructions for future reference.

3.1 Explanation of symbols

	Before any use, please refer to the relevant section of the manual.
	This symbol, placed before a safety message, indicates a precaution, warning, or danger. Ignoring it may result in injury to yourself or others. To reduce the risk of injury, fire, or electric shock, always follow the recommended safety instructions.
	DO NOT operate the engine in enclosed or poorly ventilated areas. The exhaust gas is poisonous and asphyxiating. Inhalation may be fatal.
	Petrol and its vapors are extremely flammable.
	DO NOT touch to avoid burns.
	Always wear personal protective equipment (PPE), including hearing and eye protection, when using the device.
	Wear dust protection.
	Wear sturdy footwear when using the device.
	Wear protective gloves when using the device.
	Guaranteed sound power level: 114 dB, in accordance with Directive 2000/14/EC.
	Beware of kickback (recoil).
	Avoid contact with the tip of the guide bar (chain return point), as this may cause kickback of the tool.
	DO NOT hold the tool with one hand.
	Hold the tool firmly with both hands. Place right hand on the rear handle and left hand on the front handle.
	DO NOT start or use the equipment near people (especially children) or animals. During operation, maintain a minimum distance of 10 m from others.

3.2 Risk of fire or explosion

- DO NOT smoke or allow smoking in the refueling area or near the tool when handling fuel. Never refuel the tool inside enclosed spaces such as garages, sheds, or basements to prevent the accumulation of explosive vapors.
- Gasoline and gasoline vapors are highly flammable and explosive. Extreme caution must be exercised when handling, storing, and using fuel.
- Always refuel the tool outdoors in a well-ventilated area, on stable and level ground, away from any sources of ignition such as open flames, sparks, or hot surfaces.
- Never refuel while the engine is running or the tool is still hot. Allow the engine and exhaust components to cool completely before refueling to prevent ignition of fuel vapors.
- Avoid spilling fuel during refueling. If fuel is spilled on the tool, the ground, or clothing, immediately clean the spill with appropriate materials. Change contaminated clothing at once to avoid skin irritation or fire risk.
- Inspect the fuel system regularly for leaks or damage. Replace any damaged fuel lines, fittings, or tanks immediately using manufacturer-approved parts.
- Keep a suitable fire extinguisher (class B for flammable liquids) readily accessible whenever operating or refueling the tool, especially in areas with dry vegetation or high fire risk.
- In the event of a fuel leak or fire, immediately shut off the engine if safe to do so, evacuate the area, and contact emergency services.

3.3 Risk of toxic emissions

- Always ensure proper ventilation when operating in confined spaces.
- Avoid prolonged exposure to exhaust fumes; take regular breaks in fresh air.
- Individuals with respiratory conditions should consult a physician before operation.
- Never operate the tool indoors, in basements, trenches, or other enclosed or poorly ventilated areas.
- Exhaust gases from gasoline-powered tools contain hazardous substances, including carbon monoxide—an odorless, colorless, and potentially lethal gas.

3.4 Risk of mechanical injury

3.4.1 Kickback

- Kickback may occur when the tip or end of the guide bar contacts an object, or when the wood closes in and pinches the cutting chain during operation.
- In some cases, contact with the tip of the guide bar may cause a sudden reverse reaction, forcing the bar upward and backward toward the operator.
- Pinching of the cutting chain at the upper section of the guide bar can also cause a sudden force driving the bar toward the operator.
- Either of these reactions may result in a loss of control, potentially causing serious personal injury. Never rely solely on the safety devices built into the tool. All possible precautions must be taken to avoid accidents or injuries during operation.
- Kickback is the result of improper tool use and/or incorrect operating procedures or conditions.
- The tool must always be held firmly with both hands, with thumbs and fingers wrapped securely around the handles.
- The body and arms should be positioned to absorb and control kickback forces. These forces can be managed if proper precautions are taken. The tool must not be allowed to start unexpectedly.
- Overreaching and cutting above shoulder height must be avoided. This reduces the chance of accidental tip contact and ensures better control during unexpected events.
- Only guide bars and chains specified by the manufacturer should be used. Incorrect replacements may result in chain breakage and/or kickback.
- The manufacturer's instructions for sharpening and servicing the tool must be followed. Excessive reduction of the depth gauge can significantly increase the risk of kickback.

3.4.2 Other operating warnings

- Unauthorized personnel must be kept out of the work area during operation.
- Exercise extra caution on wet, slippery, or uneven surfaces, especially after rainfall.
- Always turn off the engine before relocating the tool between work areas.
- Watch out for stumps or branches that can be thrown out during operation.
- Contact with spark plugs or ignition components during operation is strictly prohibited due to the risk of electric shock.
- Maintain a firm, two-handed grip on the tool handles, with feet positioned shoulder-width apart, to ensure proper stability and weight distribution.
- Operate the tool at the minimum engine speed necessary to perform the task. Engine speed must not exceed the required level.
- If vegetation or debris becomes entangled in any moving part, shut off the engine immediately before attempting removal.
- Avoid contact with the muffler, spark plug, or other engine components during or shortly after use, as they may reach temperatures capable of causing severe burns.
- For long-distance transport over rough terrain, drain the fuel tank completely to prevent leakage caused by vibration or impact.
- Conduct a full inspection of the work area before operation. Assess terrain conditions and remove any loose or movable obstructions.
- A fire extinguisher must be kept nearby when operating in highly flammable vegetation or during extended dry periods, due to increased fire risk.
- If equipped with a centrifugal clutch or automatic drive mechanism, maintain a firm grip when starting the engine to prevent unintentional movement.
- Establish a hazard zone with a minimum radius of 15 m/50 ft around the operation site. Unauthorized access must be restricted. Use ropes, cones, or signage as appropriate.
- When multiple operators are present, maintain clear communication and visual awareness of all personnel to ensure safe spacing.
- Start the engine at low throttle settings. After ignition, confirm that all moving parts return to a full stop when the throttle returns to idle.
- Before each use, inspect the entire tool for loose fasteners, fuel leaks, structural damage, or signs of excessive wear. Particular attention must be given to rotating or high-stress components to ensure proper installation and condition.
- Comply with all local noise regulations regarding permitted operating hours and sound levels. Recommended working periods are 08:00–17:00 on weekdays and 09:00–17:00 on weekends. Avoid operating early in the morning or late at night to reduce disturbance.

3.5 Fuel handling

- DO NOT operate if any fuel-related issue is present. Inspect the tool regularly for fuel leaks or damage to the fuel system.
- DO NOT refuel in enclosed or poorly ventilated areas. Never refuel near a water heater, furnace, or any location with a naked flame.
- DO NOT leave the fuel for a long time in the product. The fuel may clog the carburetor and the engine will not operate properly.
- Refueling must only be carried out in a safe and level location. Refueling on scaffolding, on material heaps, or other unstable or elevated surfaces is strictly prohibited.
- Fuel-soaked clothing must be removed and replaced immediately to reduce the risk of fire or skin irritation.
- Fuel spillage into the soil must be prevented to protect the environment. Always refuel on a suitable, non-permeable surface.
- Fuel is highly flammable and its vapors are explosive. Extreme caution must be exercised during storage, mixing, refueling, and transportation.
- Contact with fuel can cause injury. Any fuel that comes into contact with the body must be promptly washed off using soap and water.

- Use only clean, approved fuel containers that meet safety regulations. Fuel mixtures (e.g. gasoline and two-stroke oil) must be prepared in accordance with manufacturer recommendations and not exceed one month's supply.
- Refueling must be performed outdoors, on a flat, stable, well-ventilated surface, away from open flames, sparks, or ignition sources. Smoking is strictly prohibited.
- When the fuel is no longer used or worn, dispose of it in an authorized location. Check local laws regarding disposal of fuels.
- The tool must be shut off and allowed to cool completely before refueling. Hot engine parts or exhaust components may cause fuel spray or ignition.
- The fuel tank must not be opened and fuel must not be added while the tool is running. Remove the fuel cap slowly to release internal pressure safely.
- In the event of a fuel spill, do not attempt to start the tool. Move it away from the spill area and clean any residue thoroughly before use. Allow vapors to dissipate completely.
- During refueling, ensure the nozzle remains in contact with the tank to prevent static discharge. Wipe away any excess fuel and secure the fuel cap tightly after filling.
- Always follow the instructions in this manual for fuel type, mixing ratio, filling procedures, and safe handling practices.

3.6 General safety notes

3.6.1 Work area safety

- Keep the work area clear. Before working, inspect the work area and remove any materials or objects that could cause accidents.
- Keep people and animals away from the work area. Children and people who do not know how to use this tool should not touch it and handle it.

3.6.2 Personal safety

- DO NOT operate the tool while under the influence of alcohol, drugs, fatigue, illness, or any condition that may impair judgment or physical ability.
- DO NOT overreach or adopt unsafe working positions. Maintain a stable, well-balanced posture while working.
- Stay alert, focus on the task, and use common sense when operating power tools.
- The operator bears full responsibility for any accidents or damage caused to persons or property during operation.
- Hands and feet must be kept clear of all moving parts at all times, particularly during start-up and shutdown procedures.
- Only trained and authorized individuals who are fully familiar with all controls and their correct operation may operate the tool. Children and persons unfamiliar with the safety instructions must not use or handle the tool.
- Appropriate personal protective gear must be worn at all times during tool operation. This includes a safety helmet, face shield or protective goggles, hearing protection, gloves, non-slip footwear, and protective clothing. Workwear must be close-fitting and suitable for outdoor mechanical use. Loose or unbuttoned shirts are prohibited. Jewelry that could become entangled in moving parts must be removed. Long hair must be properly secured and covered with a safety helmet.

3.6.3 Gasoline-powered tool use and care

- Use the product only under daylight or under good artificial light.
- All handles must be kept dry, clean, and free from oil or grease to ensure safe handling.
- The tool must not be used in rainy weather, wet conditions, or poorly lit environments. Operation in the presence of flammable liquids or gases is strictly prohibited.
- This tool must only be used with accessories supplied or approved by the manufacturer. Use of unauthorized accessories may cause malfunction or injury.
- Cutting tools and accessories must be kept sharp and clean to ensure safe and efficient performance. Lubrication and replacement of accessories must be carried out in accordance with the instructions in this manual.
- Before operation, place the tool on a flat, stable, dry, and well-ventilated surface, away from flammable materials, with sufficient clearance for exhaust and debris.

- Immediately shut down the tool if the engine or ON/OFF switch malfunctions, or if abnormal sounds are detected. The tool must not be used if the starter mechanism is damaged.
- When not in use, store the tool in a locked, dry, and secure location out of the reach of children.
- Schedule work to include adequate rest intervals. Limit continuous use to 30–40 minutes per session, followed by 10–20 minutes of rest. Do not exceed two hours of tool use per day.
- Operate the tool only under appropriate conditions. Do not force the tool during operation. Avoid using the tool in poorly ventilated areas, as exhaust gases may cause injury. Do not come into direct contact with emissions released during use.

3.6.4 Service

- Have the gasoline-powered tool serviced by a qualified repair person using only identical replacement parts. This will ensure that the safety of the tool is maintained.

3.7 Maintenance and storage safety

- DO NOT disassemble or modify the tool. Unauthorized alterations may result in functional failure or hazardous conditions.
- Allow the tool to cool fully before carrying out any maintenance or storing the unit.
- Maintenance tasks must only be performed while the engine is off.
- Perform all scheduled maintenance as outlined in this manual to ensure safe and reliable tool operation.
- During maintenance, use appropriate tools and wear protective gloves when handling sharp or rotating components to prevent injury.
- When transporting or storing the tool, always install protective covers, guards, or transport locks as applicable.
- When transporting the tool, secure it properly to prevent fuel leakage, damage, or injury, and use a carrying case or protective cover to safeguard it during transportation.
- For long-term storage, the fuel tank must be completely drained. Run the engine until the carburetor is fully cleared of any residual fuel mixture.
- Store the tool in a dry, secure area, away from open flames, sparks, or any ignition sources that could ignite fuel vapors.
- During extended transport or when moving across rough terrain, the fuel tank must be emptied to prevent leaks caused by vibration or impact.
- Follow the manufacturer's instructions for maintenance and servicing of the tool. Improper maintenance or worn parts may increase the risk of operational hazards.
- Used oil, filters, and fuel containers must be disposed of only at authorized recycling or hazardous waste collection facilities, in compliance with local environmental regulations.
- Always stop the tool and wait until all moving parts come to a complete standstill before performing any inspection, maintenance, servicing, or adjustment.

3.8 Residual risks

Even when all safety precautions are followed and the tool is used properly, certain residual risks inherent to gasoline-powered tools remain:

- Use eye and face protection at all times.
- Use the tool only in well-ventilated outdoor areas.
- Take regular breaks and avoid operating when tired.
- Inhaling dust or exhaust fumes may harm respiratory health.
- Always wear approved hearing protection during operation.
- Refuel carefully, away from heat sources, and never smoke near fuel.
- Wear gloves, keep hands warm, and take regular breaks to reduce risk.
- Fuel leaks or improper handling near open flames may lead to fire or explosion.
- Long periods of operation may cause user fatigue, increasing the risk of accidents.
- Symptoms include numbness, tingling, pain, loss of strength, and skin discoloration.
- Extended exposure to high noise levels without proper hearing protection may result in hearing loss.
- Prolonged use may cause Hand-Arm Vibration Syndrome (HAVS), also known as “white finger.”
- Operation may generate flying dust, debris, or fuel splashes that can cause injury or property damage.

4. Assembly And Installation

4.1 Assembling the chain guide



WARNING: The machine must not be started during assembly. Wear protective gloves when handling the blade.

- Pull the chain brake lever toward the handle to ensure the chain brake is not engaged.
- Loosen the clutch cover nuts and remove the clutch cover.
- Install the guide bar and place the saw chain onto the drive sprocket and around the guide bar, following the direction indicated in Figure 2.
- Position the guide bar so that its hole aligns with the tensioning pin (Figure 2, Item 1). Then turn the tensioning screw clockwise to apply tension to the chain.

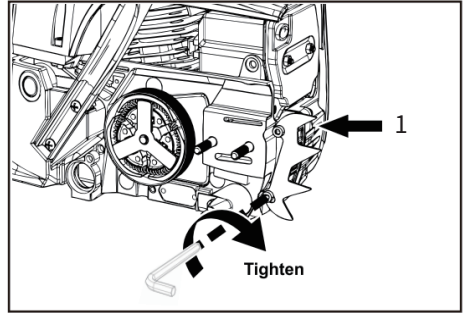
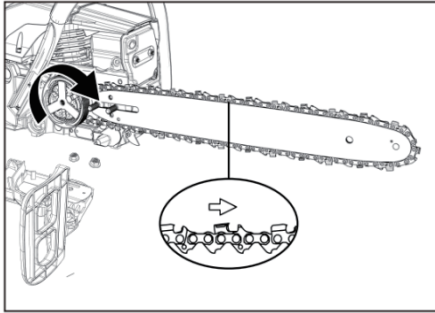

Figure 2

- Reinstall the cover and screw it with the two screws (see Figure 3).

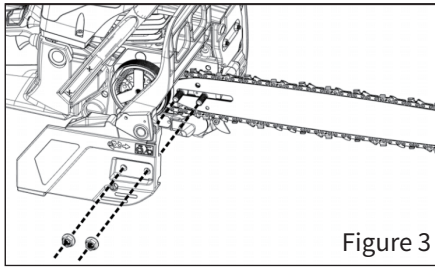

Figure 3

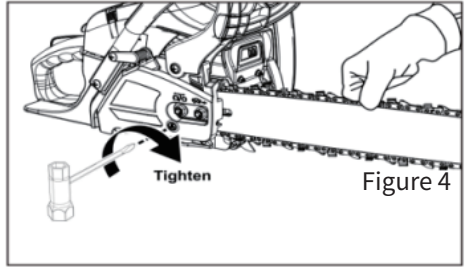

Figure 4

- Adjust the chain tension by turning the chain tensioning screw until the drive links just touch the underside of the guide bar. Ensure the chain is correctly seated and properly tensioned.
- While lifting the guide bar, turn the tensioning screw to achieve the correct chain tension.
- Then, tighten the clutch cover nuts (see Figure 4).
- Rotate the saw chain by hand to check that it moves smoothly without excessive resistance and is adequately tightened.
- If the chain is loose, repeat the installation procedure.

4.2 Adjusting the chain tension

- The tool motor must be switched off before adjusting the chain tension.
- Make sure that the chain is inside the groove of the guide.
- Hold the tip of the guide bar and adjust the chain tension using the tension adjustment screw until the chain teeth just touch the bottom of the guide bar.
- Turn the chain tension adjustment screw clockwise until the chain is tight. Never stretch the chain too much. Check the tension of the chain and check if the cover is properly tightened. If this is not the case, please repeat the procedure.

4.3 Filling the fuel tank



WARNING:

- **DO NOT refuel in a closed and unventilated area.**
- **When filling the tank, the tool must always be stopped and cooled.**
- **Never smoke during refueling. It must not have flames or sparks near the fuel.**
- **Before refueling, allow the tool to cool completely. Never attempt to refuel when the engine is hot.**
- **If fuel has been spilled, immediately stop refueling and DO NOT start the engine. Clean up the spill and fill the machine in another location**
- **Never fill the fuel tank to the flange; there is a risk of overflow.**

The fuel for this tool is a mixture of unleaded gasoline and a registered engine lubricant.

When mixing gasoline with oil, use only gasoline that does not contain ethanol or methanol. Unleaded gasoline is a high-quality fuel that helps prevent damage to the fuel lines and other engine components.

The recommended mixing ratio is 40:1. Ensure the correct mixing ratio is used before filling the product.

4.3.1 Mixing

- Mix the fuel and oil in a clean, empty container.
- First, pour the oil into the container.
- Then, add the gasoline.
- Shake or stir the mixture thoroughly for at least one minute to ensure proper blending.
- Only after mixing should the operator fill the fuel tank of the tool.

4.3.2 Filling

- Unscrew and remove the fuel tank cap.
- Slowly fill the tank with the fuel mixture. DO NOT exceed the maximum capacity (it is recommended to fill only up to 80% of the tank).
- Replace the fuel tank cap and tighten it securely.
- Wipe off any spilled fuel around the unit if necessary.



WARNING: To avoid damage or accidents, DO NOT use any other fuel mixtures or other types of oil or gasoline.

5. Operating Instructions

5.1 Starting and stopping the engine

5.1.1 Starting

- Set the switch to the “START” position (see Figure 5).
- Pull the choke lever. The choke will close and the throttle will be moved to the starting position.

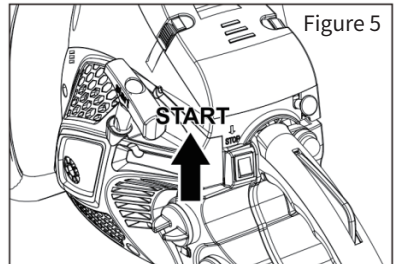

- Hold the tool firmly against the ground (see Figure 6).
- Position the tool in one of the following ways:
Place the tool on the left side of the body, holding the handle firmly with the left hand. Use the right hand to pull the starter rope.
Alternatively, place the tool on the right side of the body, holding the handle firmly with the right hand, and use the left hand to pull the starter rope (see Figure 6).
- In both cases, keep the tool away from the operator's body while pulling the starter rope.

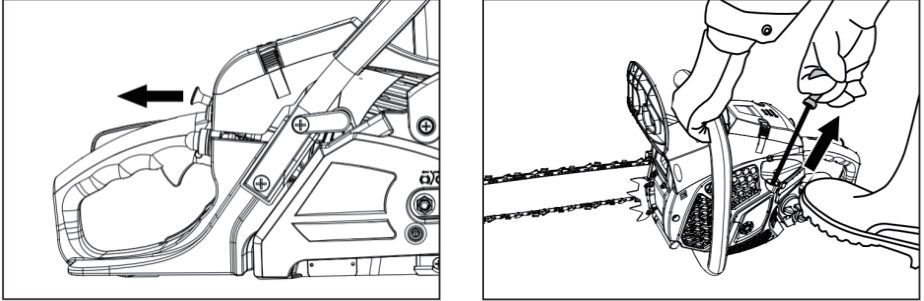

Figure 6

5.1.2 Stopping

Allow the tool to run for a few minutes. Then turn the switch to the "STOP" position (see Figure 7).

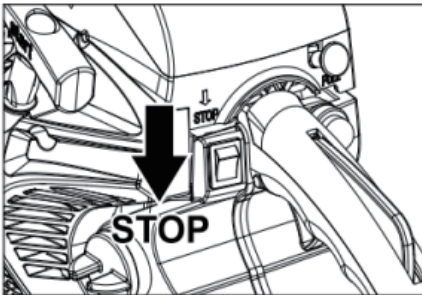

Figure 7

5.2 Adjusting the carburetor

- The carburetor is preset at the factory. To prevent malfunction, it is recommended not to alter the adjustment screws. If adjustment is necessary, have the tool serviced by an authorized service center.

5.3 Chain brake and chain

5.3.1 Chain brake

- The chain brake is a safety device that automatically stops the chain in the event of kickback, which may cause the tool to jerk backward. Normally, the brake is activated automatically by inertia.
- The chain brake can also be manually engaged by pushing the brake lever down and forward.
- While the brake is engaged, release the throttle lever to reduce engine speed.
- Continuous operation with the brake engaged may cause the clutch to overheat and result in damage.
- To resume operation, ensure the engine is switched off and cooled down, then pull the brake lever (shield) upward and backward until it clicks and locks into its original position (see Figure 8).

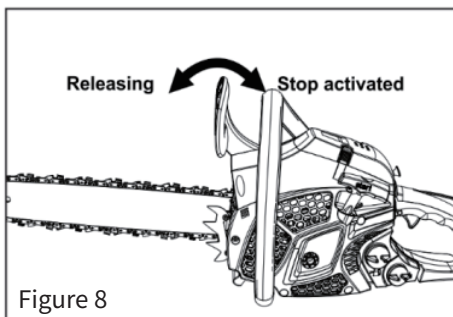

- Before each use, test the chain brake by following these steps:
Start the engine and hold the handle firmly with both hands.
While keeping the chain running by pulling the throttle control lever, push the brake lever forward using the back of the left hand.
If the brake engages and the chain stops immediately, the brake is functioning properly.
After the test, release the brake before starting work.

5.3.2 Sharpening the chain

- For optimal performance, the chain should be sharpened regularly.
- Sharpening can be performed by a professional or by the user with the aid of a proper sharpening guide, only if familiar with its correct usage.
- Sharpen the chain immediately if any of the following conditions occur:
Wood chips turn into fine dust.
Excessive force is needed to perform a normal cut.
The cutting line is not straight.
Vibration during operation increases.
Fuel consumption is noticeably higher.

5.3.3 Checking chain lubrication

- Before checking the oil flow, ensure that the bar and chain are properly installed.
- Start the engine and run it at medium speed. Check whether chain oil is being discharged and leaves visible traces on the ground.
- The oil flow rate is adjustable. Insert a screwdriver into the adjustment slot on the clutch side.
- Turn the adjuster to set an appropriate oil flow rate according to the work conditions.
- The tool should consume a full oil tank for each full fuel tank. Always refill the oil tank when refueling the machine.

5.4 Cutting work



CAUTION:

- DO NOT operate the tool for purposes other than cutting trees.
- DO NOT climb onto the tree trunk while cutting. Maintain firm footing and good balance at all times.
- If the tool becomes stuck during operation, never attempt to pull it free. Stop it and remove the obstruction using a wedge.
- Avoid working on slopes whenever possible. If work on a slope is necessary, always position above the tree trunk.
- Before bending a branch or trunk, observe the direction of the bend carefully. Complete the cut on the opposite side of the bend to prevent the chain guide from becoming pinched.

5.4.1 Tree felling

- Examine the work area and estimate the direction in which the tree will fall.
- Start the machine as described above.
- Begin by making a notch on the chosen falling side (see Figure 9).
- When the tree falls, shout or sound a warning to alert people nearby.
- Once the tree trunk begins to fall, move away from the cutting area immediately.

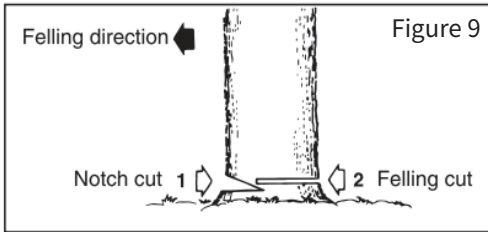

Figure 9

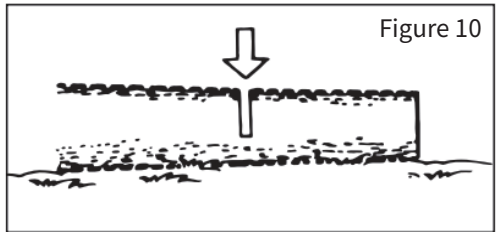

Figure 10

5.4.2 Cutting a fallen trunk

- Cut halfway through the trunk, then roll it over and complete the cut on the opposite side (see Figure 10).
- For trunks elevated off the ground, begin by cutting the first part from underneath, then cut from above (see Figure 11).
- Repeat this process for the next section.

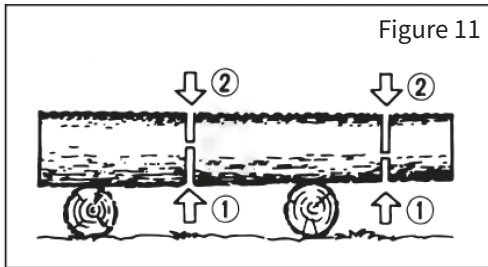

Figure 11

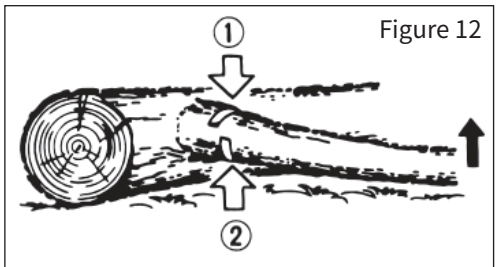

Figure 12

5.4.3 Pruning

- For pruning a felled tree, first identify the direction in which the branch is bent. Make a shallow notch on the tension side, then complete the cut from the compression side to avoid pinching the guide bar (see Figure 12).
- When pruning a standing tree, begin by making a notch from below, then finish the cut from above (see Figure 13).

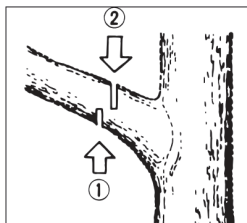

Figure 13

6. Maintenance



CAUTION:

- **DO NOT immerse the tool in water or any other liquid.**
- **Before performing any maintenance work, ensure the machine is switched off and completely cooled down.**
- **Follow the instructions below and perform maintenance regularly. A clean, well-maintained machine improves longevity and efficiency. Neglecting maintenance may cause damage, accidents, or render the tool unusable.**
- **Any other maintenance, modification, or repair work must be carried out by a qualified professional.**

6.1 After each use

- Clean engine block louvers with a blower.
- Check that the chain brake is functioning properly.
- Clean plastic parts, then wipe with a damp cloth.
- Inspect the chain guide for wear or damage.
- Check the automatic lubrication circuit for blockages.
- Examine sprocket condition.
- Clean cylinder fins using compressed air.

6.2 Cleaning the air filter

- Use compressed air to blow away dust and debris.
- To clean the foam filter, open the air filter cover, remove the foam, clean it with gasoline, wring out excess liquid, and dry thoroughly.
- Replace the foam after every 10 uses.

6.3 Cleaning the oil and fuel filters

- Regularly remove and clean both filters using clamps.
- Clean them with gasoline and reinstall properly.

6.4 Guide bar

- To clean the guide bar, remove it to clear dirt from the grooves and oiling port (see Figure 14).
- Regularly grease the pinion.

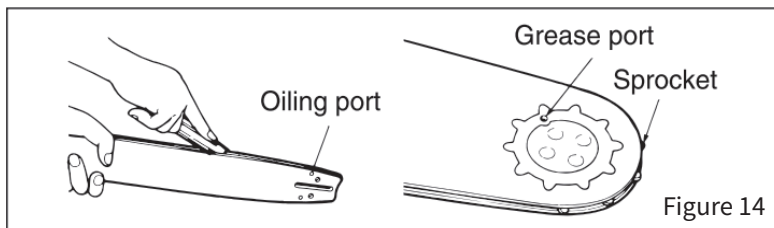

- To inspect the guide bar, periodically reverse it to ensure even wear. Use a ruler to check the bar rail's condition. If a gap is visible, the rail is in good condition; if not, the rail is worn and should be corrected or replaced (see Figure 15).

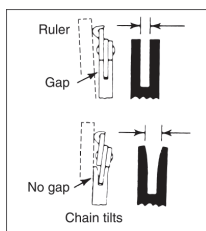

6.5 Sprocket

- DO NOT install a chain on a worn or damaged sprocket and install a worn chain on the sprocket.
- Inspect the sprocket for wear.
- If the wear depth exceeds 0.5 mm, replace the sprocket with a new one (see Figure 16).

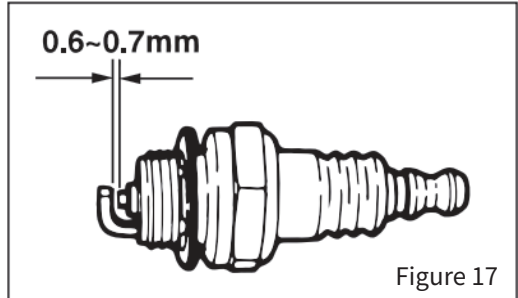
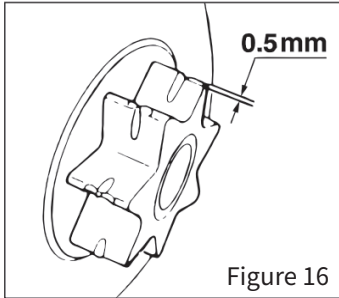

6.6 Spark plug

- Clean the electrodes with a wire brush.
- Set the electrode gap to between 0.6 mm and 0.7 mm, if necessary (see Figure 17).

6.7 Spark plug

- Check each time the cutter and cutting angles (see Figure 18).

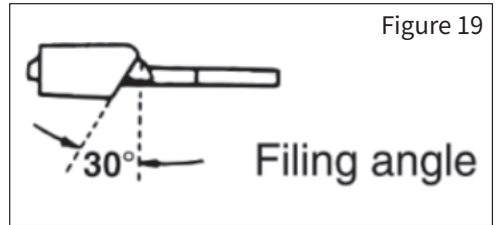
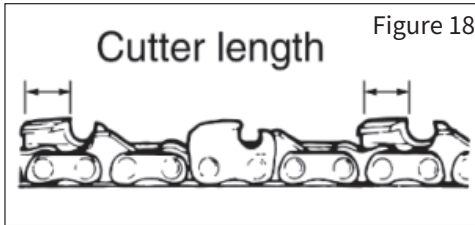

6.8 Chain sharpening

For best performance, we strongly recommend periodically sharpening the chain. The chain can be sharpened either by a professional or by yourself using a sharpening guide (make sure you know how to use it). The recommended filing angle between the file and the saw teeth is 30 degrees (see Figure 19).

The chain must be sharpened when:

- Wood chips turn into fine dust.
- Excessive force is needed to perform a normal cut.
- The cutting line is not straight.
- Vibration during operation increases.
- Fuel consumption is noticeably higher.

Sharpening method:

- Switch off and lock the tool before sharpening.
- Use a round file or a sharpening device (available in stores).
- Place the file on the tooth and push straight forward with a consistent motion.
- Repeat the same movement for each tooth.
- After sharpening all teeth, check to ensure they are sharp.

6.9 Storage

- Before storing, switch off the tool, allow it to cool, empty the fuel tank, and clean the tool thoroughly.
- Store the tool in a dry, clean place, preferably in its original packaging, and out of the reach of children.
- Store all accessories and related items together with the tool.

7. Troubleshooting

Use this section to help try and solve any problems the operator may have.

PROBLEM	POSSIBLE CAUSE	RECOMMENDED ACTION
Unit won't start or starts but will not run	Incorrect starting procedures	Follow instructions in the user guide or refer to the starting procedure check list on page 10
	Incorrect carburetor mixture adjustment setting	Have carburetor adjusted by an authorized service centre
	Fouled spark plug	Clean, gap or replace plug
	Fuel filter blocked	Replace fuel filter
	Chain brake is engaged	Pull chain brake in disengage position
Unit starts but engine has low power	Incorrect lever position on choke	Move to START position
	Dirty air filter	Remove, clean and reinstall filter
	Incorrect carburetor mixture adjustment setting	Have carburetor adjusted by an authorized service centre
Engine hesitates	Incorrect carburetor mixture adjustment setting	Have carburetor adjusted by an authorized service centre
No power under load	Incorrectly gapped spark plug	Clean, gap or replace plug
Runs erratically	Incorrect carburetor mixture adjustment setting	Have carburetor adjusted by an authorized service centre
Smokes excessively	Incorrect fuel mixture	Use properly mixed fuel (40:1 ratio)
Poor performance when operated	Blunt chain	Sharpen or replace the chain
	Loose chain	Tension the chain
Engine dies	Empty gasoline tank	Fill up the gasoline tank
	Fuel filter in the wrong position in the tank	Completely fill the gasoline tank or reposition the fuel filter in the gasoline tank
Insufficient chain lubrication (the cutter rail and chain get hot)	Empty oil tank for the chain	Top up the oil tank for the chain
	Oil lubrication opening blocked	Clean the oil lubrication hole in the guide bar
		Clean the groove in the guide bar

 **RANKOR**