

# INSTRUCTION MANUAL



## ANGLE GRINDER RAG2400701



Made in China 1025-V01  
[www.rankortools.com](http://www.rankortools.com)

**READ AND FOLLOW ALL SAFETY PRECAUTIONS IN THE INSTRUCTION MANUAL.**

Thank you for choosing **RANKOR** tools.

**RANKOR** products are renowned for their reliability, high performance, and superior quality. Our team is committed to continuous innovation, providing customers with upgraded tools and a comfortable user experience.

Before operating the tools, please read all warnings, cautions, and instructions on the tool labels and in the owner's manual. Note that the safety information provided does not cover all potential conditions or situations that may arise. Thoroughly review the owner's manual for complete safety guidelines and operating procedures. Failure to follow the instructions and safety information may lead to severe **INJURY** or **DEATH**.

## CONTENTS

<b>1. Safety Notes</b> .....	<b>3</b>
1.1 General Power Tool Safety Warnings .....	<b>3</b>
1.1.1 Work area safety .....	<b>3</b>
1.1.2 Electrical safety .....	<b>3</b>
1.1.3 Personal safety .....	<b>3</b>
1.1.4 Power tool use and care .....	<b>4</b>
1.1.5 Service .....	<b>4</b>
1.2 Safety Warnings for Angle Grinder .....	<b>5</b>
<b>2. Functional Instructions</b> .....	<b>6</b>
2.1 Operation Instructions .....	<b>6</b>
2.1.1 Wheel guard .....	<b>6</b>
2.1.2 Installing or removing grinding wheel .....	<b>6</b>
2.1.3 Side grip .....	<b>7</b>
2.1.4 Switch action .....	<b>7</b>
2.1.5 Effective and safe grinding and aanding operation .....	<b>7</b>
2.1.6 Replacing carbon brushes .....	<b>7</b>
<b>3. Maintenance &amp; Daily Care</b> .....	<b>8</b>
<b>4. Technical Data</b> .....	<b>8</b>
<b>5. Spare Parts List</b> .....	<b>9</b>
<b>6. Exploded View</b> .....	<b>10</b>

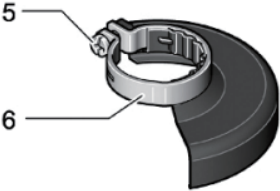
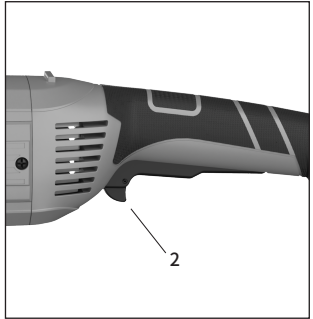

- 1. Spindle lock button
- 2. On/Off switch
- 3. Auxiliary handle
- 5. Locking screw for the protection guard
- 6. Protection guard for grinding
- 7. Mounting flange
- 8. Grinding wheel\*
- 9. Clamping nut

\* Accessories shown or described are not part of the standard delivery scope of the product. A complete overview of accessories can be found in our accessories program.

# 1. Safety Notes

## 1.1 General Power Tool Safety Warnings



### WARNING

Read all safety warnings and all instructions. Failure to follow the warnings and instructions may result in electric shock, fire, or severe injury. Save all warnings and instructions for future reference. The power tool in the warnings refers to your mains-operated (corded) power tool or battery-operated (cordless) power tool.

### 1.1.1 Work area safety

Keep the work area clean and well-lit. Cluttered or dark areas invite accidents.

Do not operate power tools in explosive atmospheres, such as in flammable liquids, gases or dust. Power tools create sparks that may ignite the dust or fumes.

Keep children and bystanders away while operating a power tool. Distractions can cause you to lose control.

### 1.1.2 Electrical safety

Power tool plugs must match the outlet. Never modify the plug in any way. Do not use any adapter plugs with earthed (grounded) power tools. Unmodified plugs and matching outlets will reduce the risk of electric shock.

Avoid body contact with earthed or grounded surfaces such as pipes, radiators, ranges and refrigerators. There is an increased risk of electric shock if your body is earthed or grounded.

Do not expose power tools to rain or wet conditions. Water entering a power tool will increase the risk of electric shock.

Do not abuse the cord. Never use the cord for carrying, pulling or unplugging the power tool. Keep the cord away from heat, oil, sharp edges and moving parts. Damaged or entangled cords increase the risk of electric shock.

When operating a power tool outdoors, use an extension cord suitable for outdoor use. Using a cord suitable for outdoor use reduces the risk of electric shock.

If operating a power tool in a damp location is unavoidable, use a residual current device (RCD) protected supply. The use of an RCD reduces the risk of electric shock.

### 1.1.3 Personal safety

Stay alert, watch what you are doing and use common sense when operating a power tool. Do not use a power tool while you are tired or under the influence of drugs, alcohol or medication. A moment of inattention while operating power tools may result in serious personal injury.

Use personal protective equipment. Always wear eye protection. Protective equipment such as dust masks, non-skid safety shoes, hard hats, and hearing protection for appropriate conditions will reduce personal injuries.

Prevent unintentional starting. Ensure the switch is off position before connecting it to the power source or battery pack or picking up or carrying the tool. Carrying power tools with your finger on the switch or energising power tools with the switch on invites accidents.

Remove any adjusting key or wrench before turning the power tool on. A wrench or a key left attached to a rotating part of the power tool may result in personal injury.

Do not overreach. Keep proper footing and balance at all times. This enables better control of the power tool in unexpected situations.

Dress properly. Do not wear loose clothing or jewellery. Keep your hair, clothing and gloves away from moving parts. Loose clothes, jewellery or long hair can be caught in moving parts.

If devices are provided for connecting dust extraction and collection facilities, ensure these are connected and properly used. The use of dust collection can reduce dust-related hazards.

### **1.1.4 Power tool use and care**

Don't force the power tool. Use the correct power tool for your application. The correct power tool will do the job better and safer at the rate for which it was designed.

Do not use the power tool if the switch does not turn on and off. Any power tool that cannot be controlled with the switch is dangerous and must be repaired.

Disconnect the plug from the power source or the battery pack from the power tool before making any adjustments, changing accessories, or storing power tools. Such preventive safety measures reduce the risk of starting the power tool accidentally.

Store idle power tools out of the reach of children and do not allow persons unfamiliar with the power tool or these instructions to operate the power tool. Power tools are dangerous in the hands of untrained users.

Maintain power tools. Check for misalignment or binding of moving parts, breakage of parts and any other condition that may affect the power tool's operation. If damaged, have the power tool repaired before use. Poorly maintained power tools cause many accidents.

Keep cutting tools sharp and clean. Properly maintained cutting tools with sharp edges are less likely to bind and are easier to control.

Use the power tool, accessories, tool sets, etc., in accordance with these instructions, taking into account the working conditions and the work to be performed. Using the power tool for operations different from those intended could result in a hazardous situation.

### **1.1.5 Service**

Have your power tool serviced by a qualified repair person using only identical replacement parts. This will ensure that the safety of the power tool is maintained.

## 1.2 Safety Warnings for Angle Grinder

**Do not avoid comfort or familiarity, gained from repeated use of the product, to override strict adherence to grinding safety rules. Using this tool unsafely or incorrectly may result in serious personal injury.**

Always use the proper guard with the grinding wheel. A guard protects the operator from broken wheel fragments.

Accessories must be rated for at least the speed recommended on the tool warning label. Wheels and other accessories running over the rated speed can fly apart and cause injury.

Hold the tool by the insulated gripping surfaces when performing an operation where the cutting tools may contact hidden wiring or its own cord. Contact with a "live" wire will make exposed metal parts of the tool "live" and shock the operator.

When using depressed center grinding wheels, be sure to use only fiberglass reinforced wheels.

Always use safety glasses or goggles. Ordinary eye or sun glasses are not considered safety glasses.

Check the wheel carefully for cracks or damage before operation. Replace any cracked or damaged wheels immediately. Run the tool (with guard) at no load for about a minute to test for any flaws. Hold the tool away from others; if the wheel is flawed, it will likely break apart during this test.

Use only flanges specified for this tool.

Be careful not to damage the spindle, the flange (especially the installing surface), or the outer flange. Damage to these parts could result in wheel breakage.

**NEVER** use this tool with wood cutting blades or other saw blades. Such blades, when used on a grinder, can frequently kick back and cause loss of control leading to personal injury.

Hold the tool firmly. Paints and wood can expose the user to dust containing hazardous substances. Use appropriate respiratory protection.

Keep hands away from rotating parts.

Ensure the cord is clean and free of the wheel. Do not wrap the cord around your arm or wrist. If control of the tool is lost, the cord may become wrapped around you and cause personal injury.

Make sure the wheel is not in contact with the workpiece before the switch is turned on, ensure that the tool is properly installed and secure. Before using the tool on an actual workpiece, let it run for a while to check for any vibration or wobbling that could indicate poor installation or a poorly balanced wheel.

Use the specified surface of the wheel to perform the grinding.

Watch out for flying sparks. Hold the tool so that sparks fly away from you and other persons or flammable materials.

Do not leave the tool running. Operate the tool only when hand-held.

Do not touch the workpiece immediately after operation; it may be extremely hot and could burn your skin.

**ALWAYS** wear proper apparel, including long-sleeve shirts, leather gloves, and shop aprons to protect your skin from contact with grindings.

Use this tool for grinding or sanding certain products. Paints and wood can expose the user to dust containing hazardous substances. Use appropriate respiratory protection.

## 2. Functional Instructions



### WARNING

Misuse or failure to follow the safety rules stated in this instruction manual may cause serious personal injury.

## 2.1 Operation Instructions

### 2.1.1 Wheel guard

Please align the convex end of the wheel guard with the slot opening of the front cover. Then, rotate the guard body by 180 degrees and finally tighten the fastening screw (Fig 1 and Fig 2).

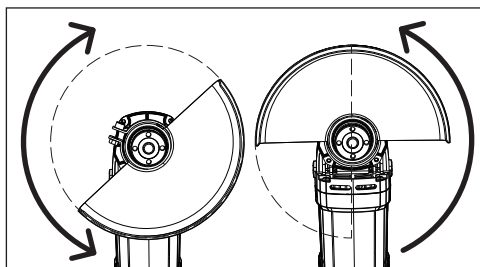

Fig 1

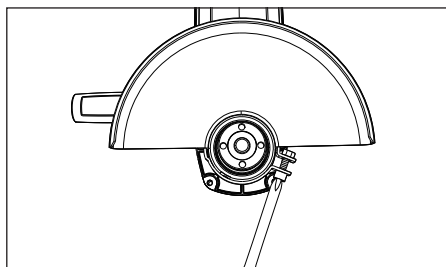

Fig 2

### 2.1.2 Installing or removing grinding wheel

**CAUTION:** When using an abrasive cut-off wheel, be sure to use only the supplied wheel guard, inner flange, and outer flange designed for use with cut-off wheels.

1. Mount the inner flange onto the spindle, fit the wheel/disk onto the inner flange, and screw the outer flange onto the spindle (Fig 3).
2. To tighten the outer flange, press the shaft lock firmly so that the spindle cannot revolve. Then, use the lock nut wrench to securely tighten it clockwise (Fig 4).
3. To remove the wheel, follow the installation procedure in reverse.

**NOTES:** The groove of the INNER FLANGE must align with the flatness of the spindle when you install the wheel and tighten it sufficiently.

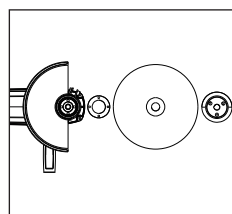

Fig 3

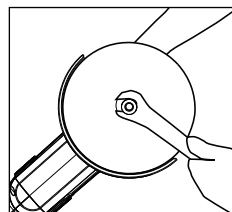

Fig 4

### 2.1.3 Side grip

**CAUTION:** Always ensure that the side grip is installed securely before operation. The tool's head is designed with three screw holes on both sides and the top side to facilitate the assembly of the grip. Screw the side grip securely into the position shown in the Fig 5. Hold the side grip firmly by hand throughout the operation to maintain better control of the tool.

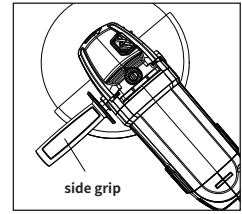

Fig 5

### 2.1.4 Switch action

**CAUTION:** Before plugging in the tool, always check to ensure that the switch trigger functions properly and returns to the "OFF" position when released. The switch can be locked in the "ON" position for ease of operator comfort during extended use. Exercise caution when locking the tool in the "ON" position and maintain a firm grasp on the tool.

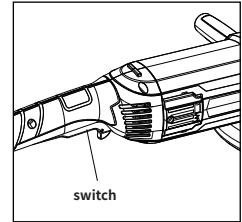

Fig 6

### 2.1.5 Effective and safe grinding and aanding operation

Always hold the tool firmly with one hand on the housing and the other on the side handle. Turn the tool on and then apply the wheel or disc to the workpiece. Don't operate the tool under the condition of removing the wheel guard.

- 1.Users can achieve satisfactory results if they apply only half the strength compared to the tool's own weight. Exerting too much strength can easily damage the tool's engine and the abrasive wheel due to overload.
- 2.Generally, it is recommended to keep the grinding and cutting part of the wheel and disc within a range of 15 to 30 degrees relative to the surface of the processing object. (Fig 7)
- 3.In general operation, the tool should be started first, then the workpiece should be approached. In reverse, the workpiece should be left before stopping the tool.

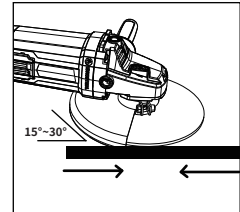

Fig 7

### 2.1.6 Replacing carbon brushes

- 1.Regularly remove and check the carbon brushes. Replace them when the tool produces obvious sparks or when the brush cover wears down to the limit mark (Fig 8).
- 2.Both carbon brushes should be replaced at the same time.
- 3.Always send this tool to an authorized service center for replacement, or have it replaced by an experienced worker.

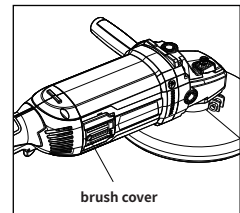

Fig 8

**CAUTION:** Be sure to re-install the knob after inserting new carbon brushes. After replacing the brushes, plug in the tool and break in the brushes by running the tool with no load for about 3 minutes. Then check the tool while it is running; when releasing the switch trigger, if the tool is not working well, ask your local service center for repair.

To maintain product SAFETY and RELIABILITY, repairs, any other maintenance, or adjustments should be performed by Authorized or Factory service centers.

## 3. Maintenance & Daily Care



### CAUTION

Always ensure that the tool is switched off and unplugged before attempting to perform any inspection and maintenance.

- 1.The tool and its air vents must be kept clean. Regularly clean the tool's air vents or whenever the vents begin to become obstructed.
- 2.Check all screws periodically to see if they are loosened or not.
- 3.Regularly check the cord insulation for any signs of damage, specifically looking for breaks or cracks.

## 4. Technical Data

Model No.	RAG2400701
Voltage	220-240V~
Frequency	50/60Hz
Rated Power	2400W
No Load Speed	8500/min
Max. Disc Diameter	180mm

\* Measured without protection guard and auxiliary handle. The values given are valid for a nominal voltage [U] of 230 V. For different voltages and models for specific countries, these values can vary.

## 4. RAG2400701 Angle Grinder Spare Parts List

Exploded View NO.	Part Name	QTY	Exploded View NO.	Part Name	QTY
1	Outer Flange	1	28	Bearing Flange	1
2	Grinding wheel	0	29	Fad Guid	1
3	Inner Flange	1	30	Armature	1
4	Wheel cover	1	31	Ring	1
5	Output shaft	1	32	Bearing	1
6	Key	1	33	Bearing Sleeve	1
7	Dust cover	1	34	Screw	2
8	Screw	4	35	Stator	1
9	Bearing holder	1	36	Motor Housing	1
10	O-Ring	1	37	Carbon Brush Holder	2
11	bearing	1	38	Screw	4
12	Screw	7	39	Carbon Brush	2
13	bearing Flange	1	40	Coil Spring	2
14	Big gear	1	41	Carbon Brush Cap	2
15	spring ring	1	42	Soft Start	1
16	bearing	1	43	Right Handle	1
17	Gear cover	1	44	Screw	4
18	O-Ring	1	45	Terminal	1
19	Self-locking pin	1	46	Switch	1
20	Self-locking spring	1	47	Wire Plate	1
21	Self-locking cap	1	48	Screw	2
22	Screw	4	49	Cord Guard	1
23	Nut	1	50	Power Cord	1
24	Pinion	1	51	Left Handle	1
25	washer	1	52	Auxiliary Handle	1
26	bearing	1	53	Hex key	1
27	Washer	1	54	Wrench	1

# 5. RAG2400701 Angle Grinder Exploded View

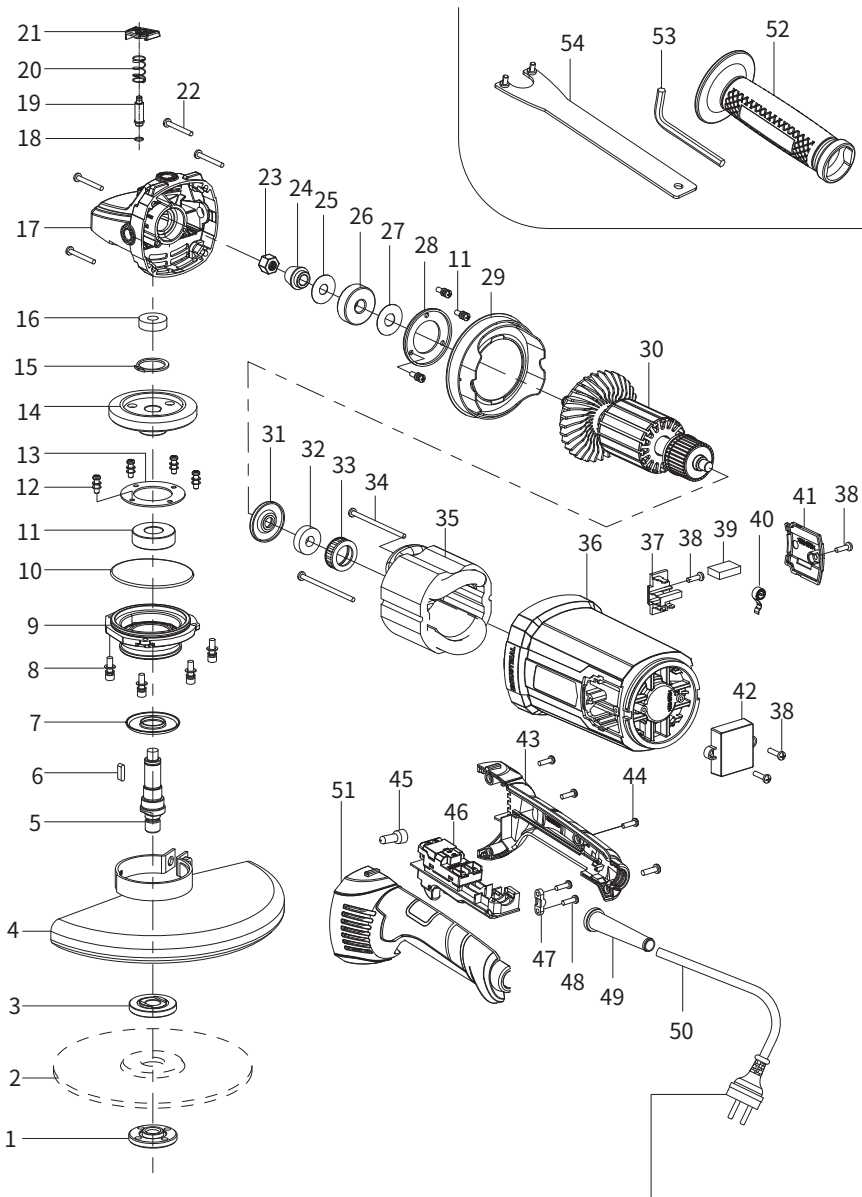

Power cord plug types vary according to regional standards and regulations.  
Please refer to the actual product for the specific configuration.

